



Brief introduction :

The ball valve is designed and manufactured according well to API 6D. Floating ball when small caliber, and fixed ball when large caliber. It has fire protection structure and antistatic device. Widely used for petroleum, chemistry, water treatment industries.

Main part & material

Part name	Material
body	WCB,ZG1Cr18Ni9Ti,CF8
ball	1Cr18Ni9Ti 304,316
stem	1Cr18Ni9Ti 304,316
seal ring	Polytetrafluoroethylene (PTFE)
packing	Polytetrafluoroethylene (PTFE)

PRODUCT – BALL VALVE

3pc Ready-Package Ball Valve

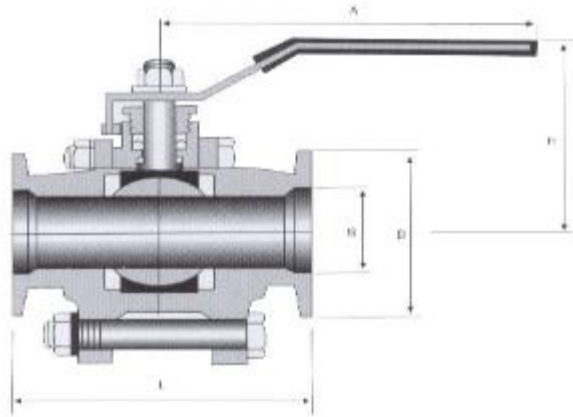

Main outer size mm

DN	G	D	L	H	A
15	1/2"	34	95	68	125
20	3/4"	50.5	105	70	125
25	1"	50.5	115	80	145
32	1-1/4"	50.5	125	84	145
40	1-1/2"	50.5	135	93	205
50	2"	64	150	100	205
65	2-1/2"	77.5	190	142	250
80	3"	91	220	155	250
90	3-1/2"	106			
100	4"	119			

Specification

Nominal pressure(Mpa)	PN	2.5,4.0,6.4
Strength testing pressure(Mpa)	PT	3.8,6.0,9.6
Low pressure seal test(Mpa)		0.6
High pressure seal test(Mpa)		3.0,4.8,7.6
Applicable medium	water, oil, gas, nitric acid, acetic acid	
Applicable temperature	-40 ~ 180 °C	



Office Address
SAIF ZONE | PO Box 8047
Sharjah, UAE.
Skype: Unitech Trading (unitechtrading)
Tel / Fax 00971-6-544-8882
Email <mailto:info@unitechtrading.com>

PRODUCT – BALL VALVE

3pc Ready-Package Ball Valve

Feature:

-Anti-blowout Structure of Valve Stem

When medium pass through the valve, the pressure in valve body may possibly push the stem out, or when the valve is in repair, if there is pressure in the middle cavity, the stem or medium seems to easily fly out upon disassembling the valve, which can cause injures to human

beings, To prevent the possibilities, a dummy club is packing and thrust bearing are burnt or packing is damaged due to other causes, the pressure of medium in valve body will make the dummy club of valve stem in close contact with the upper seal face of valve body. Thus

to prevent medium leaking out from the damage packing position.

-Reliable Seal Structure

The seat is made of PTFE. Because the contact area between seat and the ball will becomes more high with rising of pressure of the middle cavity, Small Resistance ball valve has the smallest resistance of all the valve, in the case of reduced bore, the resistance is little still.

-Prompt switch

The ball valve circumrotates in 90°, It work quickly to open or close.